



OWNER'S GUIDE



S7200HRT
SUSPENSION ELLIPTICAL™
TRAINER

Congratulations on choosing a VISION FITNESS Suspension Elliptical™ Trainer. You've taken an important step in developing and sustaining an exercise program! Your Suspension Elliptical™ Trainer is a tremendously effective tool for achieving your personal fitness goals. Regular use of your Suspension Elliptical™ Trainer can improve the quality of your life in so many ways...

Here are just a few of the health benefits of aerobic exercise:

- Weight Loss
- A Healthier Heart
- Improved Muscle Tone
- Increased Daily Energy Levels
- Reduced Stress
- Help in Countering Anxiety and Depression
- An Improved Self Image

The key to reaping these benefits is to develop an exercise habit. Your new Suspension Elliptical™ Trainer will help eliminate the obstacles that prevent you from getting in your exercise time. Neither bad weather or darkness will interfere with your workout when you have your Suspension Elliptical™ Trainer in the comfort of your home. This Owner's Guide provides you with basic information on starting an exercise program. A more complete knowledge of your new Suspension Elliptical™ Trainer will assist you in realizing your goal of a healthy lifestyle.

Please contact your authorized VISION FITNESS retailer should service be required. If a question or problem arises which cannot be handled by your VISION FITNESS retailer, please contact us:

VISION FITNESS
1600 Landmark Drive
Cottage Grove, WI 53527
Ph: 1.800.335.4348
Fax: 1.608.839.8731
www.visionfitness.com

Table of Contents.....

ALL MODELS

SAFETY INSTRUCTIONS.....	4
POWER REQUIREMENTS.....	5
ASSEMBLY & MOVING.....	6
PLACEMENT, STABILIZING, & POWER.....	7
CONTACT HEART RATE.....	8
VARIABLE INCLINE.....	9

S7200HRT CONSOLE

CONSOLE OVERVIEW.....	10
CONSOLE DESCRIPTIONS.....	11
ON/OFF SWITCH.....	13
PROGRAM OVERVIEWS.....	14
USING THE PROGRAMS.....	18
USING THE SPRINT 8 PROGRAM.....	20
USING HEART RATE TRAINING.....	21
USING THE HEART RATE CHEST STRAP.....	22
ALL HRT® PROGRAMS.....	23
USING THE USER PROGRAMS.....	25
USING THE GOAL PROGRAMS.....	26
ENGINEERING MODE.....	28

GENERAL

PREVENTATIVE MAINTENANCE.....	29
TROUBLESHOOTING.....	30
TROUBLESHOOTING HEART RATE CHEST STRAP.....	31
HOME WARRANTY.....	32
CORPORATE WARRANTY.....	34
DEVELOPING A FITNESS PROGRAM...	36
EXERCISE GUIDELINES.....	37
TARGET HEART RATE.....	38
BALANCED FITNESS.....	39

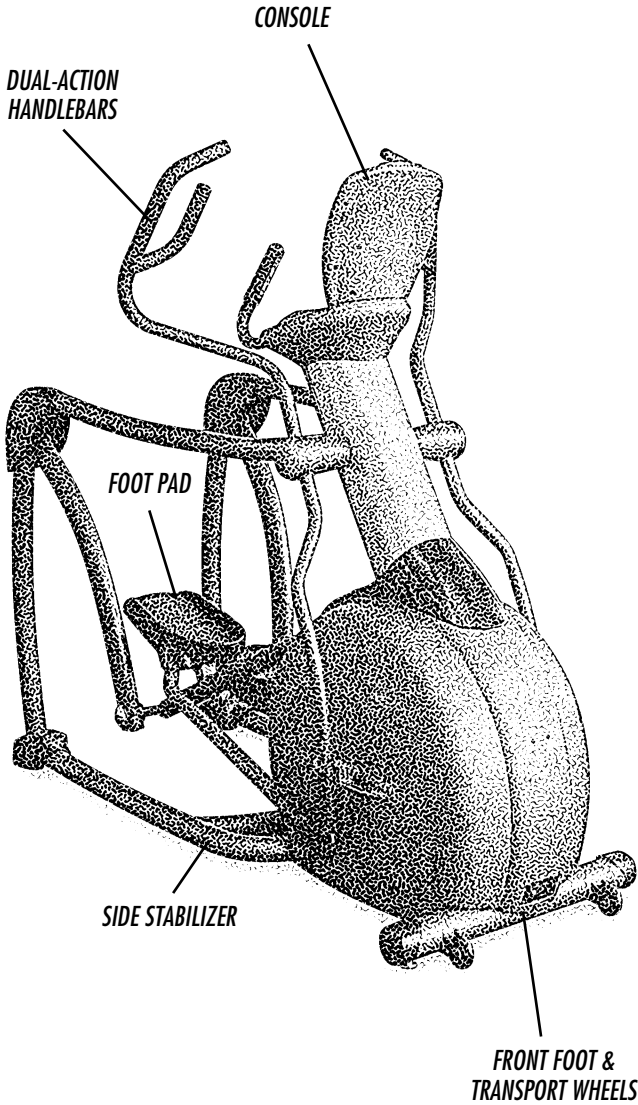

S7200HRT

SUSPENSION ELLIPTICAL TRAINER

IMPORTANT SAFETY INSTRUCTIONS

SAVE THESE INSTRUCTIONS

When using an electrical product, basic precautions should always be followed, including the following:

Read all instructions before using this exercise product.

WARNING! To reduce the risk of burns, fire, electrical shock or injury to persons:

- Use this exercise product for its intended use as described in this Owner's Guide. Only use attachments recommended by the manufacturer.
- Never drop or insert any object into any opening.
- Do not remove the Suspension Elliptical™ Trainer sidecovers. Service should be performed only by an authorized VISION FITNESS retailer.
- Never operate this Suspension Elliptical™ Trainer if it has a damaged cord or plug, if it is not working properly, or if it has been damaged or immersed in water. Please contact your authorized VISION FITNESS retailer for service.
- Keep the cord away from heated surfaces.
- Do not use outdoors.
- To disconnect, turn the switch to the OFF position, then remove plug from outlet.
- Only use the power cord provided with your VISION FITNESS Suspension Elliptical™ Trainer.
- Never place the power cord under carpeting or place any object on top of the power cord that may pinch and damage it.
- Unplug your Suspension Elliptical™ Trainer when not in use and before moving it.

CHILDREN

- Keep children off your Suspension Elliptical™ Trainer at all times.
- When the Suspension Elliptical™ Trainer is in use, young children and pets should be kept at least 10 feet away.

OTHER SAFETY TIPS FOR YOUR VISION FITNESS SUSPENSION ELLIPTICAL TRAINER

CAUTION! If you experience chest pains, nausea, dizziness or shortness of breath, stop exercising immediately and consult your physician before continuing.

- Do not wear loose clothing that might catch on any part of the Suspension Elliptical™ Trainer.
- Read this Owner's Guide before operating this Suspension Elliptical™ Trainer.

CLEANING

- Clean only with mild soap and a slightly damp cloth; never use solvents.

SAFETY MODE

Your *S7200HRT* is equipped with a Safety Mode that keeps your *S7200HRT* in its highest resistance level while not in use to help prevent the pedals from being moved. By default this mode is disabled, but it can be enabled in the Engineering menu (see Page 28).

POWER REQUIREMENTS

This product is for use on a nominal 120-volt circuit, and has a grounding plug that looks like the plug illustrated below. An improper connection of the equipment grounding conductor can result in a risk of an electrical shock. Do not modify the plug that was provided with this product. If this plug does not fit into your outlet, have a qualified electrician install the proper outlet. Adapters, extension cords and surge protectors should not be used with this product. **NOTE:** 120V is for use in North America. This product may take 120V or 220V power in other regions.

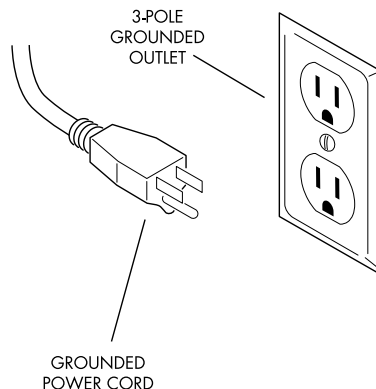

ASSEMBLY

It is recommended, when possible, that an authorized VISION FITNESS retailer assemble your Suspension Elliptical™ Trainer. If you have elected to assemble this product yourself, for your safety, please read and follow each of the steps in the enclosed assembly instructions. If you have any questions regarding any component or function of your Suspension Elliptical™ Trainer, contact your retailer.

MOVING

Your VISION FITNESS Suspension Elliptical™ Trainer has transport wheels included for ease of mobility. To move, firmly grasp the rear of the frame assembly. Carefully lift and roll on the transport wheels.

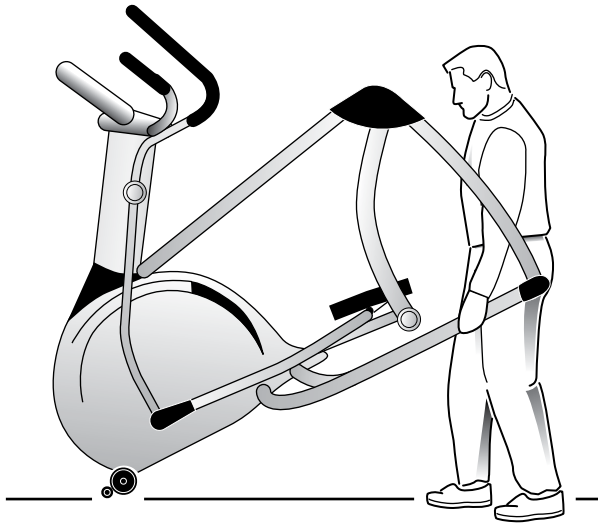

CAUTION: Our Suspension Elliptical™ Trainers are well-built and heavy, weighing up to 300 pounds! Use care and additional help if necessary.

PLACEMENT IN YOUR HOME

Please follow the safety instructions to place the Suspension Elliptical™ Trainer in the location where it will best be used. It is important that you place your Suspension Elliptical™ Trainer in a comfortable and inviting room. Avoid putting your Suspension Elliptical™ Trainer in an unfinished basement or undesirable setting. Exercise adherence will be easier to achieve only if you exercise in an attractive setting.

STABILIZING THE SUSPENSION ELLIPTICAL TRAINER

After positioning the Suspension Elliptical™ Trainer in its intended location, check the unit's stability. Rocking or wobbling indicates that your Suspension Elliptical™ Trainer needs to be leveled. Determine which leveler is not resting completely on the floor. Loosen the nut at the base of the leveler to allow the leveler to rotate. Now rotate the leveler to the left or right until the Suspension Elliptical™ Trainer is stable. Lock the adjustment by tightening the nut against the support tube.

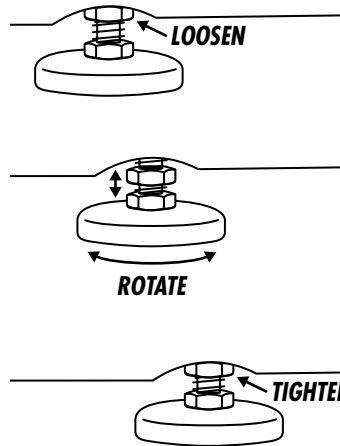

TURNING THE UNIT ON AND OFF

Use the power switch on the front of the unit to turn the machine ON and OFF. It is recommended to turn the machine off when not in use.

NOTE: You can also turn the power off at the console.

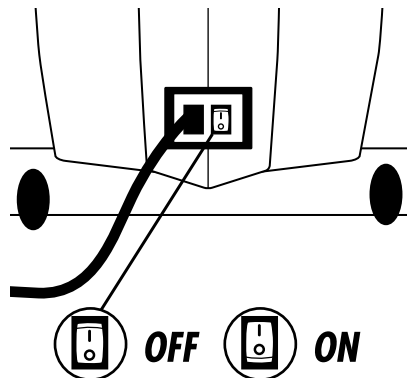

CONTACT HEART RATE

HAND PULSE HEART RATE SENSORS

The Contact Hand Pulse Sensors are included on each product to monitor your heart rate. To use, grasp both of the sensors with a comfortable grip during your workout. The console will display your heart rate. It may take the system a few seconds to zero in on your actual heart rate. Most people have a grip that is conductive enough to transmit a good signal. However, some people have erratic heart rates or improper body chemistry to transmit a good signal through the touch sensitive hand pulse grips.

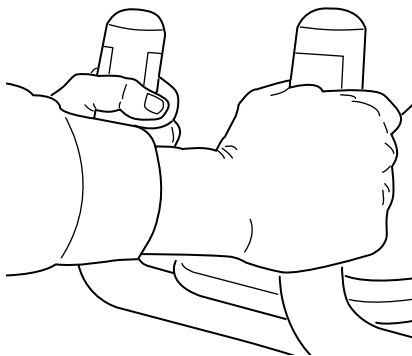

VARIABLE INCLINE

Press the INCLINE UP or DOWN arrows to adjust the incline from level 1 to 24. This incline setting represents a range of motion.

Incline changes are not immediate. They will take time to get to the target incline angle.

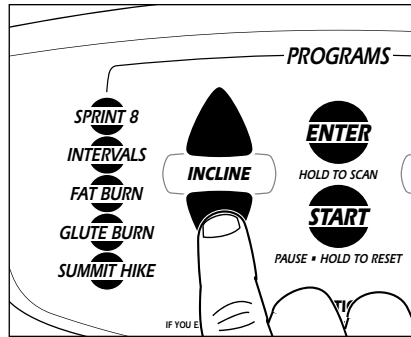

S7200HRT CONSOLE

DISPLAY CONSOLE OVERVIEW

The computerized display allows the user to select a workout that meets their desired fitness goals. It also allows the user to monitor the progress and feedback of each workout so they can track improvements in overall fitness over time.

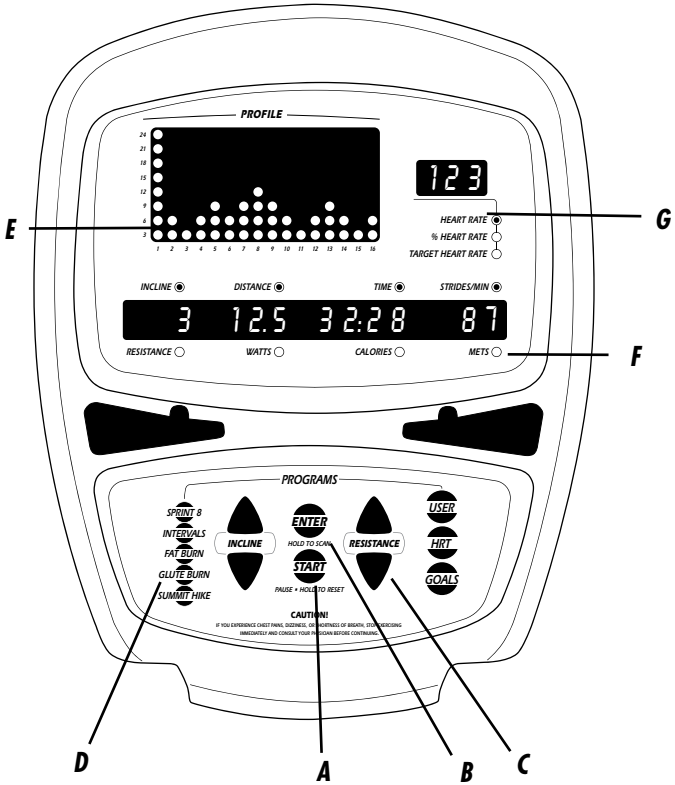

S7200HRT

S7200HRT CONSOLE DESCRIPTIONS

A. START/HOLD TO RESET

Press the START key to begin a MANUAL workout immediately without having to set individual information. When the program begins, you have the ability to adjust resistance and incline levels with the ARROW keys.

PAUSE: If you need to PAUSE your program during a workout, pressing the START key will PAUSE your program for five minutes. Pressing START will return you to your workout.

RESET: If you need to RESET the console during your workout, you can do so by holding down the START key for three seconds or until the display resets.

B. ENTER/HOLD TO SCAN

This key is used after entering each piece of information in setup such as age, weight, or level.

SCAN: When exercising in a program, pressing the ENTER key will allow you to SCAN the feedback display views. If you hold down the ENTER key for three seconds during your workout, the SCAN function will automatically alternate feedback display views.

C. ARROW KEYS

These keys are used to change values in setup mode prior to your workout. During your workout, they are used to change workout levels. In HRT® programs, they are used to change your target heart rate.

D. PROGRAM KEYS

These keys provide quick access to your favorite workouts. There is no need to scroll through the programs to find the one you want. Simply press the program key and begin user setup.

S7200HRT CONSOLE DESCRIPTIONS (continued)

E. PROFILE DISPLAY

This window provides a dot matrix profile of the workout segments you are about to complete, as well as those you have already completed, and the level of resistance for each segment.

F. MESSAGE/FEEDBACK WINDOWS

These windows provide step-by-step instructions in the setup mode, instructions, feedback and motivational messages during your workout.

FEEDBACK:

During your workout, these windows display exercise feedback about your workout, including:

TIME: the time elapsed or the time remaining in your workout.

DISTANCE: the total distance traveled in miles or kilometers since the start of your workout.

STRIDES/MIN: your stride rate or strides per minute.

WATTS: a measurement of workload; one watt is equal to six kilogram-meters per minute.

CALORIES: an estimate of calories burned since the beginning of the workout.

RESISTANCE: the current resistance level of your workout.

INCLINE: the level of incline. There are 24 levels that represent a 23% grade change.

METS: a measurement of oxygen consumption; one MET equals the approximate amount of oxygen consumed per minute by a person at rest.

G. HEART RATE/HRT FEEDBACK WINDOW

This window provides feedback on your current heart rate and the percent of your predicted maximum heart rate (% Heart Rate). It also includes your target heart rate when using one of the HRT® programs on this product.

ON/OFF SWITCH Turn your Suspension Elliptical™ Trainer off if you will not use it for an extended period of time.

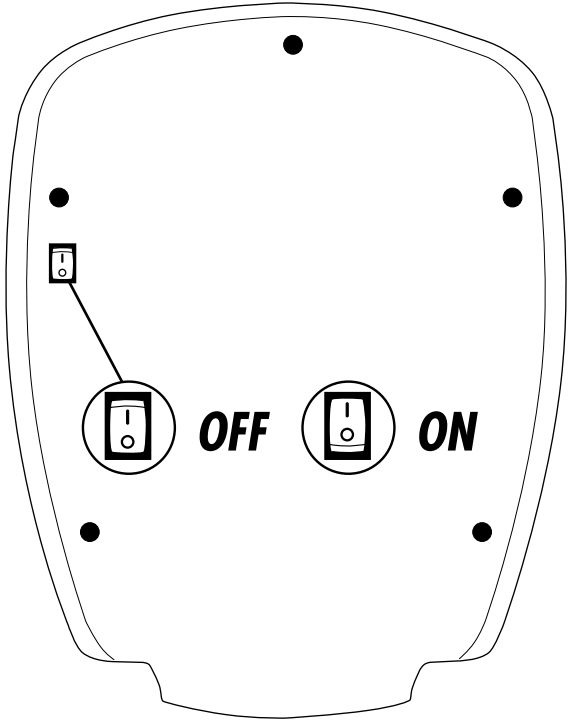

S7200HRT

THE S7200HRT PROGRAMS

PROGRAM OVERVIEWS

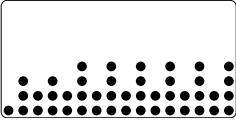

SPRINT 8 is an anaerobically-based interval program. It is effective in recruiting fast twitch muscle fibers and improving athletic performance.

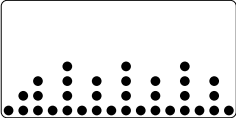

INTERVAL is an efficient workout that strengthens your cardiovascular system by alternating work intervals and recovery intervals. Be sure to challenge yourself with intense work intervals.

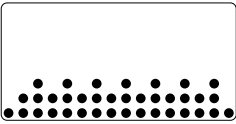

FAT BURN is a program designed to target your stored body fat. This program is generally used at a slightly lower resistance level but runs for longer durations than other programs.

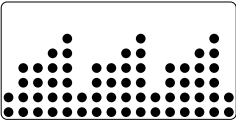

GLUTE BURN is a challenging program designed to tone the lower half of the body. This program includes incline changes and user prompts for maximum effectiveness.

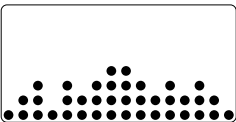

SUMMIT HIKE is a variable incline program that adds variety and targets your muscles from different angles.

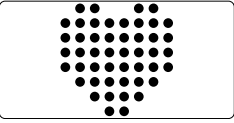

HRT CARDIO is a high-intensity program that keeps you at the upper range of your predicted maximum heart rate and promotes cardiovascular endurance and maximum calorie burning. The user must grasp the hand

pulse sensors or wear a telemetric heart rate chest strap during use. The program will automatically adjust resistance to keep you at 80% of your predicted maximum heart rate.

HRT WEIGHT LOSS is a lower intensity workout that will help your body burn a higher percentage of calories from your body's fat reserves. The user must grasp the hand pulse sensors or wear a telemetric heart rate chest strap during use. The program will automatically adjust resistance to keep you at 65% of your predicted maximum heart rate.

HRT INTERVAL alternates between effort intervals of 80% and 70% of your predicted maximum heart rate. This program is designed to increase your cardiovascular fitness capacity. The user must grasp the hand pulse sensors or wear a telemetric heart rate chest strap during use.

HRT HILL increases your intensity level from 65%, to 70%, to 75%, to 80% of your predicted maximum heart rate to promote cardiovascular strength and endurance. The user must grasp the hand pulse sensors or wear a telemetric heart rate chest strap during use.

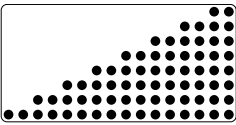

CUSTOM allows you to preset up to four workout programs by setting the resistance and profile of each segment in the program. You have the ability to save or change the workouts whenever you wish. CUSTOM will

save your resistance and incline changes throughout the program. Every 30 seconds your settings will be saved to provide an identical program for your next exercise session.

GOAL PROGRAMS

TARGET GOALS

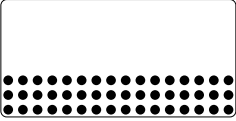

TIME, DISTANCE, CALORIES are essentially manual programs in which duration is determined by your particular goal.

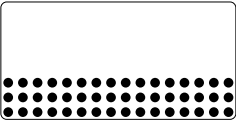

WATTS is a program that lets the user exercise at a set work level. As you increase your strides per minute, your resistance will decrease; if you decrease your strides per minute, your resistance will increase.

MUSCLE GOALS

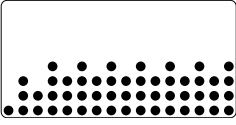

CALF TONER

The CALF TONER program was created to do just that, tone your calf and lower leg while burning calories necessary to give you slimmer legs. This program utilizes eight 45 second SETS of increased resistance along with direction changes to place emphasis on the muscles in the lower legs. Standing on the balls of the feet during these sets is an effective way to further recruit these lower leg muscles.

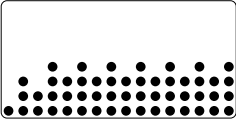

QUAD TONER

The QUAD TONER program was designed to target the Quadriceps muscle group, increasing strength and muscle tone through eight 45 second sets of increased resistance and incline changes while simultaneously burning calories and working the cardiovascular system. This combination of strength and aerobic exercise will lead to more eye-catching and defined legs.

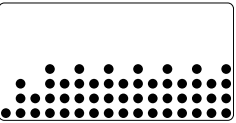

TOTAL BODY

The TOTAL BODY program has eight 45 seconds sets that use changes in body position, resistance, and incline to target all the muscle groups in your body. This program is great for overall strength and conditioning.

USING THE PROGRAMS

SELECTING EASY START

The easiest way to begin exercising is to simply press the START key. You will begin exercising in a MANUAL resistance program in which you can change the resistance levels to meet your goals. Current default settings will be used to determine exercise feedback.

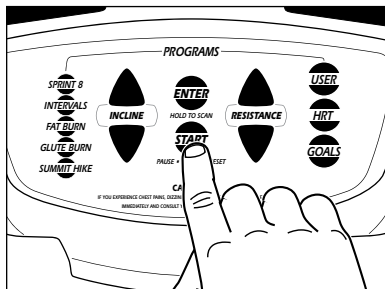

SELECTING A PROGRAM

Each program has its own program key. Press the key of the program you would like to use. You can also use the arrow keys to scroll through the program options and see the exercise profiles for each of the programs.

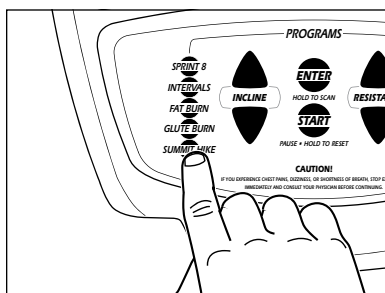

ENTERING AGE

When prompted by the message center to enter your age, use the UP ▲ arrow or DOWN ▼ arrow to adjust displayed age to the correct value. This information is necessary for the HRT® programs and will affect your "% Heart Rate" feedback.

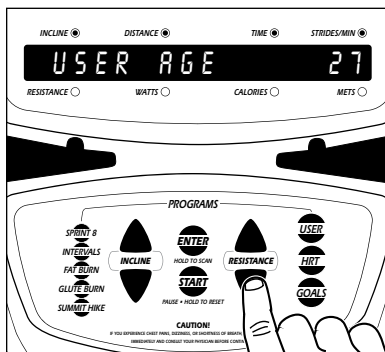

USING THE PROGRAMS (continued)

ENTERING TIME

When prompted by the message center to enter a time, use the UP ▲ arrow and DOWN ▼ arrow to adjust the displayed exercise time to a desired value.

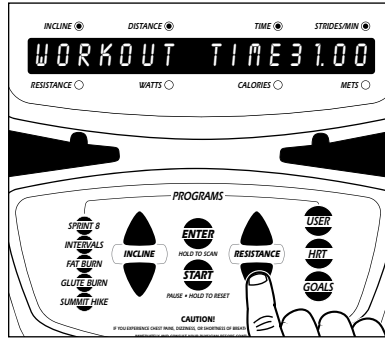

ENTERING LEVEL

When prompted by the message center to enter level, use the UP ▲ arrow and DOWN ▼ arrow to adjust the displayed resistance level. There are 24 levels of resistance to choose from in each program. The maximum resistance level varies by program.

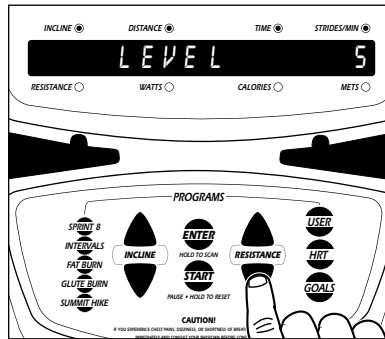

ENTERING WEIGHT

When prompted by the message center to enter weight, use the UP ▲ arrow and DOWN ▼ arrow to adjust the displayed weight to equal your current body weight. This information is necessary to give accurate exercise feedback for calorie and MET calculations.

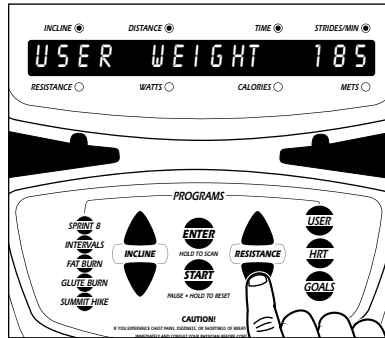

The HRT® programs will set your target heart rate in the place of resistance level. The console will display your target heart rate and give you the opportunity to adjust this value if you wish.

USING THE SPRINT 8 PROGRAM

The Sprint 8 program is an anaerobic interval program designed to build muscle, improve speed, and naturally increase the release of Human Growth Hormone (HGH) in your body. Producing HGH through exercise and a proper diet has been shown as an effective way to burn fat and build lean muscle mass according to Phil Campbell, author of *Ready, Set, Go! Synergy Fitness*. Please go to Mr. Campbell's website www.readysetgofitness.com for more details about this radical new approach to fitness.

The SPRINT 8 program features intense sprint intervals followed by recovery intervals. The program includes the following phases:

1. **WARM-UP** should gradually increase your heart rate and increase respiration and blood flow to working muscles. The warm-up is controlled by the user to meet your specific needs.
2. **INTERVAL TRAINING** starts immediately after the warm-up with a 30-second Sprint interval. Seven Recovery Intervals of 90 seconds will alternate with the eight 30-second Sprint Intervals. The message display will prompt you to increase your stride rate during the Sprint Interval and decrease stride rate during the Recovery Interval. A difference of 40 to 60 Strides Per Minute between Sprint Interval and Recovery Interval is recommended.
3. **COOL-DOWN** helps return your body's systems to resting levels. Less demand is placed on your heart during recovery if an appropriate cooldown is used following the exercise.

Due to the fact that this is a specialized training program, total workout time is not displayed during the program. The interval time is displayed in the time window instead. It takes only 20 minutes to complete the SPRINT 8 workout.

USING HEART RATE TRAINING

WHAT IS HEART RATE TRAINING?

Heart Rate Training means exercising at an intensity that keeps you in your ideal heart rate zone. Your personal heart rate training zone depends on your fitness goal, such as weight loss, cardiovascular endurance, or strength building. Refer to page 38 for more information on heart rate training zones. VISION FITNESS HRT® programs are set up to keep you at an ideal heart rate based on your fitness goal. These programs automatically adjust resistance based on your heart rate readings.

The S7200HRT console features four programs (HRT Weight Loss, HRT Cardio, HRT Interval, and HRT Hill) that offer the benefits of Heart Rate Training.

- *These programs use the predicted maximum heart rate formula (220 minus age) to determine your predicted maximum heart rate. Some individuals have higher or lower maximum heart rates than determined by this formula. The programs allow you to modify your Target Heart Rate to achieve your personal goals.*

HAND PULSE HEART RATE SENSORS

The Contact Hand Pulse Sensors are included on each product to monitor your heart rate. To use, grasp the sensors with a comfortable grip during your workout. The console will display your heart rate. Although your signal will be displayed immediately, it may take the system a few seconds to zero in on your actual heart rate.

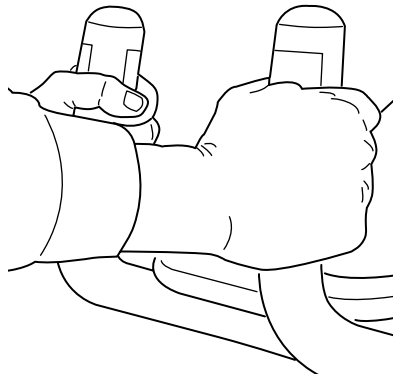

NOTE: The Contact Hand Pulse Sensors will work for the HRT® programs, but it is recommended to use the telemetric chest strap for an uninterrupted signal and ease of use.

TELEMETRIC HEART RATE CHEST STRAP

The wireless Telemetric Chest Strap uses a pair of electrodes on the underside of the strap to send your heart rate signal to the console. Prior to wearing the chest strap, moisten the two rubber electrode pads with several drops of water. These electrodes must remain wet to provide an accurate signal. We advise using the chest strap against your skin, but it also functions through a thin layer of wet clothing.

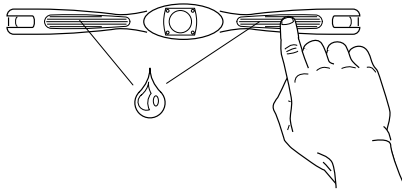

STRAP PLACEMENT

Center the transmitter strap just below the breast or pectoral muscles, directly over your sternum with the VISION FITNESS logo facing out. Adjust the elastic strap so it is snug but comfortable enough for proper breathing.

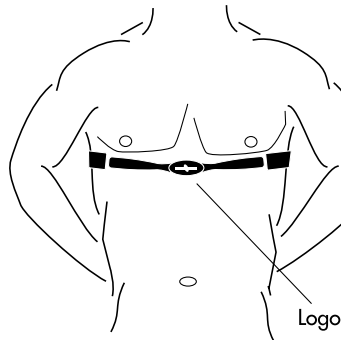

ALL HRT PROGRAMS

During the workout, the user will grasp the hand pulse sensors or wear the telemetric chest strap to send their heart rate signal to a receiver in the console. The console will continuously monitor the heart rate, adjusting the resistance level of the Suspension Elliptical™ Trainer to keep your heart rate within several beats of your Target Heart Rate. By using the SCAN key, the heart rate feedback window conveniently displays your Heart Rate, % Heart Rate, and your Target Heart Rate to keep you informed about your current heart rate. Each program will begin with a two-minute warm-up. When the workout time has been completed, the console will begin a five-minute cool-down. The user will be responsible for adjusting resistance to meet their needs during the warm-up and cool-down.

ADJUSTING TARGET HEART RATE

While exercising in one of the HRT® programs, after the two-minute warm-up, you may decide the Target Heart Rate needs to be adjusted. To adjust your Target Heart Rate, use the UP ▲ or DOWN ▼ arrow keys. Push ENTER to select.

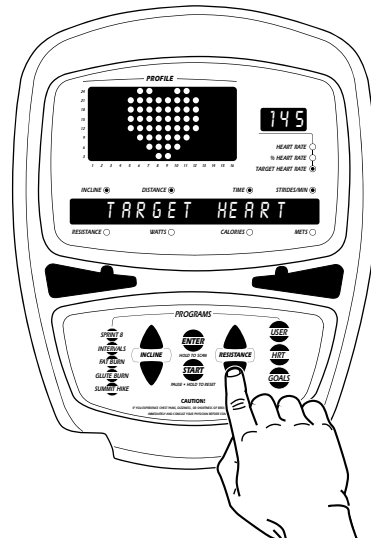

HRT CARDIO

The HRT CARDIO program is designed to maintain your heart rate at 80% of your predicted maximum heart rate. It is intended to improve efficiency and endurance of your cardiovascular system by working your heart, lungs and circulatory systems. This is a great workout for anyone, but beginners may want to start lower and build their way up to 80% of their predicted maximum heart rate.

HRT WEIGHT LOSS

The HRT WEIGHT LOSS program is designed to maintain your heart rate at 65% of your predicted maximum heart rate. The goal of this program is to burn calories by using your body's fat reserves as the primary fuel during exercise and to improve the efficiency of your workout by eliminating over-training or under-training. This is a great workout for beginners.

HRT INTERVAL

The HRT INTERVAL program is designed to increase aerobic endurance and your overall fitness level, increase endurance of muscle fibers, and increase the amount of calories burned in your exercise session. This program consists of alternating effort and recovery intervals. The Target Heart Rate for your effort interval will be 80% of your predicted maximum heart rate, while the Target Heart Rate for your recovery intervals will be 70% of your predicted maximum heart rate. The two-minute effort interval begins when you reach your Target Heart Rate for that particular interval. The recovery interval duration depends on the amount of time it takes to get to your recovery heart rate.

HRT HILL

The HRT HILL program uses four different Target Heart Rates to build cardiovascular strength and endurance. The resistance will adjust until your rate reaches the Target Heart Rate for four separate hills. The hills will be set at 65%, 70%, 75%, and 80% of your predicted maximum heart rate. The program will keep you at each heart rate level for one minute from the time the Target Heart Rate is reached. The program will repeat the series of hills until the workout time is complete.

USING THE USER PROGRAMS

The USER programs allow four separate programs to be set and stored for future use.

Set-up for the USER program requires you to select from one of the four USER programs. You will then go through set-up mode like any other program, setting age, workout time and user weight.

When you press START and begin and will run similar to a manual program. You will need to adjust both resistance and incline throughout the program. Your setting will be recorded every 30 seconds. At the end of your workout the message center will ask you to PRESS AND HOLD ENTER TO SAVE. This will allow you to save your most recent workout, or keep the workout that was saved previously.

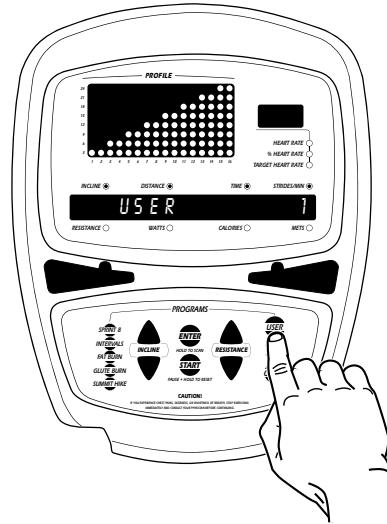

GOAL PROGRAMS

There are two types of GOAL programs, Target Goals and Muscle Goals.

USING THE TARGET GOAL PROGRAMS

The Target Goal programs allow you to select one of four target goals for your workout. The target goals include: Time, Calories, Distance, and Watts. You will be asked your goal choice in set-up. You will then go through set-up mode like any other program, setting age, user weight, and resistance level.

For the Time, Calories, and Distance programs, the workout will then begin and will run until your goal has been achieved. These programs run like a MANUAL program in which you will need to adjust resistance and incline for intensity changes.

For the Watts program, as you increase your strides per minute, your resistance will decrease; if you decrease your strides per minute, your resistance will increase.

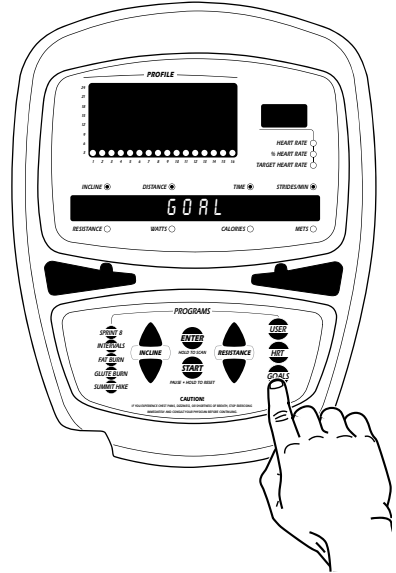

USING THE MUSCLE GOAL PROGRAMS

These programs were designed to work independently as individual workouts or collectively as a weekly exercise routine promoting weight loss and development of a toned upper and lower body in only 25 minutes a day. The different muscle programs are so effective because they alternate cardiovascular exercise intervals with SETS of higher intensity exercise that use resistance, incline, and direction changes to target specific muscle groups stimulating strength gains, increased muscle tone, and greater calorie expenditures.

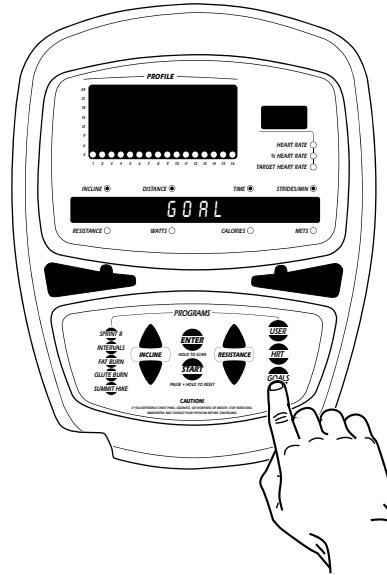

S7200HRT ENGINEERING MODE

Engineering consists of optional settings and information used by service technicians to assure your product is working in proper order. There are also several default settings that allow you to customize the Suspension Elliptical™ Trainer to fit your needs.

ENTERING AND USING ENGINEERING MODE

- Press and hold the UP ▲ and DOWN ▼ RESISTANCE ARROW keys simultaneously for three seconds.
- The console will beep and bring you into engineering mode. Use the UP ▲ and DOWN ▼ RESISTANCE ARROW keys to scroll through the various engineering options.
- Press the ENTER key to select the appropriate engineering option.
- Use the UP ▲ and DOWN ▼ RESISTANCE ARROW keys within each setting to modify the setting
- Press and hold the ENTER key to save the setting.
- To exit engineering mode, press and hold the START key for three seconds.

ENGINEERING OPTIONS INCLUDE:

SETTING	DESCRIPTION
HARDWARE TEST	TEST USED BY SERVICE TECHNICIANS TO TEST ECB SYSTEM
LED TEST	TEST USED BY SERVICE TECHNICIANS TO TEST LED DISPLAY
DEF TIME SET	SET THE DEFAULT WORKOUT TIME
DEF LEVEL SET	SET THE DEFAULT RESISTANCE LEVEL
DEF AGE SET	SET THE DEFAULT USER AGE
DEF WEIGHT	SET THE DEFAULT USER WEIGHT
BEEPER MODE	TURN THE BEEPER ON OR OFF
SPEED MODE	SET THE FEEDBACK INFO TO ENGLISH (MILES) OR METRIC (KILOMETERS)
MACHINE MODE	SET TO BIKE OR ELLIPTICAL TRAINER
DOT DISP MODE	SET DOT MATRIX DISPLAY WHEN NOT IN USE
ACC TIME	MEASURES TOTAL TIME IN HOURS OF USE
ACC DIST	MEASURES TOTAL DISTANCE TRAVELED ON THE UNIT
INCLINE TEST	TESTS AT ZERO, MIN., AND MAX.
AUTO-CALIBRATE	AUTO-CALIBRATION OF ELEVATION MOTOR TO SET MIN, MAX AND ZERO POSITIONS
INCLINE RESET	ALLOWS YOU TO TURN ON OR OFF THE INCLINE RESET AT THE END OF THE WORKOUT
SAFETY MODE	ALLOWS YOU TO SET UNIT SO RESISTANCE IS FULLY ENGAGED WHEN NOT IN USE

SERVICE AND TROUBLESHOOTING

PREVENTATIVE MAINTENANCE TIPS

- Locate Suspension Elliptical™ Trainer in a cool, dry place.
- Make sure all bolts and fasteners are kept tight.
- Keep the display console free from fingerprints and salt build-up caused by sweat.
- Use a cotton cloth with water and a mild cleaning product to clean the Suspension Elliptical™ Trainer. Other fabrics, including paper towels, may scratch the surface. Do not use ammonia or acid-based cleaners.
- Clean the exterior of the machine thoroughly on a regular basis.

PREVENTATIVE MAINTENANCE SCHEDULE

Follow the schedule below to ensure proper operation of the product.

<i>ITEM</i>	DAILY	MONTHLY	BI-ANNUALLY	ANNUALLY
DISPLAY CONSOLE		CLEAN		
ALL BOLTS AND HARDWARE			INSPECT	
FRAME		CLEAN		INSPECT
HANDLEBARS		CLEAN		
PLASTIC COVERS		CLEAN		
FOOTPLATES		CLEAN		
POWER CORD				INSPECT

TROUBLESHOOTING

Our Suspension Elliptical™ Trainers are designed to be reliable and easy to use. If, however, you have a problem, these troubleshooting steps may reveal the cause.

PROBLEM: The console does not light up.

SOLUTION: Check to make sure the power switch located on the backside of the console is turned on.

SOLUTION: Make sure the power cord is plugged into the base of the Suspension Elliptical™ Trainer, and the power switch located near the plug is on.

SOLUTION: Make sure the wire harness is plugged into the back of the console.

PROBLEM: You feel a thump or hitch in the stride motion.

SOLUTION: Check assembly and tightness of all hardware.

SOLUTION: Check the bolts and the bracket under the footplate.

NOTE: If the above steps fail to remedy the problem, discontinue use, turn the power off and contact your retailer.

TROUBLESHOOTING YOUR HEART RATE MONITOR CHEST STRAP

PROBLEM: No pulse reading appears.

SOLUTION: There may be a poor connection between the contact pads and skin. Remoisten the contact pads.

SOLUTION: Transmitter is not properly positioned; reposition the chest strap.

SOLUTION: Verify that the distance between the transmitter and receiver is not beyond the recommended range of 36 inches.

PROBLEM: There is an erratic pulse rate.

SOLUTION: Chest strap is too loose; readjust according to directions.

NOTE: It is possible that heart rate monitors will not function properly on some people for a variety of reasons. It may be necessary to experiment with the fit and position of the chest strap. Outside interference sources such as computers, motors, electric dog fences, home security systems, remote controls, CD players, fluorescent lights, etc., may cause problems for heart rate monitors.

LIMITED HOME USE WARRANTY*

VISION FITNESS extends the following exclusive, limited warranty, which shall apply only to the use of the device in the home, for residential, non-commercial purposes only. Any other use of the device shall void this warranty.

VISION FITNESS hereby extends the following limited warranties for the following components of the device, for the time period indicated:

FRAME - LIFETIME VISION FITNESS warrants the Frame against defects in workmanship and materials for the life of the product, so long as it remains in the possession of the original owner.

ECB-PLUS™ BRAKE - LIFETIME VISION FITNESS warrants the ECB-PLUS™ Magnetic Brake against defects in workmanship and materials for the life of the product, so long as it remains in the possession of the original owner. Only the Brake and Magnet assembly, and no other ancillary components or parts, are covered by this lifetime warranty.

ELECTRONICS & PARTS - FIVE YEARS VISION FITNESS warrants the Electronic components and all original Parts (other than the ECB-PLUS™ Magnetic Brake) against defects in workmanship and materials for a period of five years from the date of original purchase, so long as the device remains in the possession of the original owner.

LABOR - ONE YEAR VISION FITNESS shall cover the Labor cost for the repair of the device for a period of one year from the date of original purchase, so long as the device remains in the possession of the original owner.

*Limited Home Use Warranty valid in North America Only

LIMITED HOME USE WARRANTY (continued)

EXCLUSIVE REMEDY

The exclusive remedy for any of the above warranties shall be repair or replacement of defective Parts, or the supply of Labor to cure any defect, provided that Labor shall be limited to one year. All Labor shall be supplied by the local Retailer who sold the Product, and the Product must be located within that Retailer's service area. Products located outside the Retailer's service area will not be covered by the Labor warranty.

EXCLUSIONS AND LIMITATIONS

This warranty applies only to the original owner and is not transferable. This warranty is expressly limited to the repair or replacement of a defective Frame, ECB-PLUS™ Magnetic Brake, Electronic component, or defective Part and is the sole remedy of the warranty. The warranty does not cover normal wear and tear, improper assembly or maintenance, or installation of parts or accessories not originally intended or compatible with the Fitness Product as sold. The warranty does not apply to damage or failure due to accident, abuse, corrosion, discoloration of paint or plastic, or neglect. VISION FITNESS shall not be responsible for incidental or consequential damages. Parts and Electronic components reconditioned to As New Condition by VISION FITNESS or its vendors may sometimes be supplied as warranty replacement parts and constitute fulfillment of warranty terms. Any warranty replacement parts shall be warranted for the remainder of the original warranty term.

VISION FITNESS expressly disclaims all other warranties, express or implied, including but not limited to all warranties of fitness for a particular purpose or of merchantability. This warranty gives you specific legal rights, and your rights may vary from state to state.

WARRANTY REGISTRATION

Your warranty card must be completed and sent to VISION FITNESS before a warranty claim can be processed. You may also register via our website at www.visionfitness.com. Inside the enclosed warranty card, you will find a customer survey. Your care in completing the survey will be of value to us in serving you in the future. Comments and suggestions are always welcome. We are certain you will enjoy your new Suspension Elliptical™ Trainer. Thank you for selecting a VISION FITNESS product.

LIMITED CORPORATE WARRANTY*

Up to 3 hours use per day

CORPORATE USES DEFINED VISION FITNESS warrants model *S7200HRT* for use in corporate facilities including: Hotels; Resorts; Police & Fire Stations; Apartment Complexes; Corporate Fitness Centers; Hospitals; Rehabilitation and Sports Medicine Clinics, where average use is up to three hours per day. Not warranted for private Health Clubs, YMCA's or Schools.

FRAME, ECB-PLUS™ BRAKE, ELECTRONICS & PARTS - ONE YEAR

VISION FITNESS warrants the Frame, ECB-PLUS™ Magnetic Brake, Electronic components and all original Parts against defects in workmanship and materials for a period of one year from the date of original purchase, so long as the device remains in the possession of the original owner.

LABOR - ONE YEAR VISION FITNESS shall cover the Labor cost for the repair of the device for a period of one year from the date of original purchase, so long as the device remains in the possession of the original owner.

EXCLUSIVE REMEDY

The exclusive remedy for any of the above warranties shall be repair or replacement of defective Parts, or the supply of Labor to cure any defect, provided that Labor shall be limited to one year. All Labor shall be supplied by the local Retailer who sold the Product, and the Product must be located within that Retailer's service area. Products located outside the Retailer's service area will not be covered by the Labor warranty.

*Limited Corporate Warranty valid in North America Only

LIMITED CORPORATE WARRANTY (continued)

Up to 3 hours use per day

EXCLUSIONS AND LIMITATIONS

This warranty applies only to the original owner and is not transferable. This warranty is expressly limited to the repair or replacement of a defective Frame, ECB-PLUS™ Magnetic Brake, Electronic component, or defective Part and is the sole remedy of the warranty. The warranty does not cover normal wear and tear, improper assembly or maintenance, or installation of parts or accessories not originally intended or compatible with the Fitness Product as sold. The warranty does not apply to damage or failure due to accident, abuse, corrosion, discoloration of paint or plastic, or neglect. VISION FITNESS shall not be responsible for incidental or consequential damages. Parts and Electronic components reconditioned to As New Condition by VISION FITNESS or its vendors may sometimes be supplied as warranty replacement parts and constitute fulfillment of warranty terms. Any warranty replacement parts shall be warranted for the remainder of the original warranty term.

VISION FITNESS expressly disclaims all other warranties, express or implied, including but not limited to all warranties of fitness for a particular purpose or of merchantability. This warranty gives you specific legal rights, and your rights may vary from state to state.

WARRANTY REGISTRATION

Your warranty card must be completed and sent to VISION FITNESS before a warranty claim can be processed. You may also register via our website at www.visionfitness.com. Inside the enclosed warranty card, you will find a customer survey. Your care in completing the survey will be of value to us in serving you in the future. Comments and suggestions are always welcome. We are certain you will enjoy your new Suspension Elliptical™ Trainer. Thank you for selecting a VISION FITNESS product.

DEVELOPING A FITNESS PROGRAM

By purchasing this piece of VISION FITNESS exercise equipment, you have made a commitment to exercise and now have the convenience of exercising in your own home. Your new equipment offers the flexibility to exercise at whatever time suits you best. It will be easier to maintain a consistent exercise program that will help you achieve your fitness goals.

ACHIEVING YOUR FITNESS GOALS

An important step in developing a long-term fitness program is to determine your goals. Is your primary goal to lose weight? Improve muscle tone? Relieve stress? Prepare for the spring racing schedule? Knowing what your goals are will help you develop a more successful exercise program. If possible, try to define your personal goals in precise, measurable terms over specific periods of time. Examples of these goals might include:

- Decrease your waistline by two inches over the next two months.
- Run the local 5K race this summer.
- Get 30 minutes of cardiovascular exercise at least five days per week.
- Improve your race time by two minutes over the next year.
- Move from walking a mile to jogging a mile within the next three months.

The more specific the goal, the easier it will be to track your progress. If your goals are long-term, divide them into monthly and weekly segments. Long-term goals can lose some of the motivational benefits. Short-term goals are easier to achieve and will allow you to see the progress you are making. Every time you reach a goal, it is important to set a new goal. This will lead to a healthier lifestyle and will provide the motivation that you will need to move forward.

TRACK YOUR PROGRESS

Now that you have set your exercise goals, it is time to write them down and make an exercise schedule that will help you achieve them. By keeping a fitness diary, you will stay motivated and know where you are in terms of reaching your goals. As time goes on, you will be able to look back with pride to see how far you've come. For your convenience, we have included exercise log sheets in the wellness tools section of our website at www.visionfitness.com.

EXERCISE GUIDELINES

EXERCISE DURATION

A common question asked is, “how much exercise do I need?” We recommend following the guidelines set up by the American College of Sports Medicine (ACSM) for healthy aerobic activity.

- Exercise three to five days per week.
- Warm up for five to 10 minutes before aerobic activity.
- Maintain your exercise activity for 30 to 45 minutes.
- Gradually decrease the intensity of your workout, then stretch to cool down during the last five to 10 minutes.

If weight loss is a major goal, participate in your aerobic activity at least 30 minutes for five days each week.

EXERCISE INTENSITY

The next question asked is, “how hard do I need to work out?” To reap the most cardiovascular benefits from your workout, it is necessary to exercise within a recommended intensity range. We recommend monitoring your exercise heart rate to measure exercise intensity.

TARGET HEART RATE

Target Heart Rate is a percentage of your maximum heart rate. Target Heart Rate will vary for each individual depending on age, current level of conditioning, and personal fitness goals. Exercise heart rate should range from 55% to 85% of your maximum heart rate. As a point of reference, we use the predicted maximum heart rate formula of (220 minus age) to determine your heart rate training zone. Please use the following chart to determine your predicted Target Heart Rate.

Percentage of Maximum Heart Rate	10	20	30	40	50	60	70	80	90	100
85%	178	170	161	153	144	136	127	119	110	102
75%	157	150	142	135	127	120	112	105	97	90
65%	136	130	123	117	110	104	97	91	84	78
55%	115	110	104	99	93	88	82	77	71	66
AGE	10	20	30	40	50	60	70	80	90	100

EXAMPLE:

If you are a 30-year-old, your predicted maximum heart rate is 190 based on the (220 minus age) formula.

$$220 - 30 = 190$$

Based on the chart above, your heart rate training zone is 104 to 161, which is 55%–85% of 190.

BALANCED FITNESS

While cardiovascular exercise has been the primary method of fitness for many programs over the years, it should not be the only method. Strength Training and Flexibility Training have become more popular as exercise has developed. Incorporating Strength and Flexibility Training into your current exercise program will give you the balance you need to improve your athletic performance, reduce susceptibility to injury, increase metabolic rate, increase bone density, and reach your goals faster.

STRENGTH TRAINING

Strength Training was once known as an activity performed by young males only. That has changed with the advances in scientific research on Strength Training over the last 20 years or so. Research has proven that, after age 30, we begin to lose muscle mass if we do not incorporate Strength Training into our exercise program. With this decrease in muscle mass, our ability to burn calories decreases, our physical ability to do work decreases and our susceptibility to injuries increases. The good news is that, with a proper Strength Training program, we can maintain or even build muscle as we age. A proper Strength Training program will work the muscle groups of the upper and lower body. There are now many options available for Strength Training including: yoga, Pilates, selectorized machines, free weights, stability balls or medicine balls, exercise tubing and body weight exercises, just to name a few.

Recommendations for a minimum Strength Training program include:

FREQUENCY: Two to three days per week

VOLUME: One to three sets consisting of eight to 12 repetitions.

accessible

smooth

versatile

*it all
starts
with a
vision*

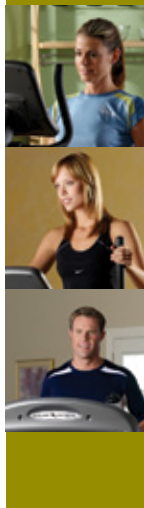

1600 Landmark Drive ■ Cottage Grove, WI 53527

toll free 800.335.4348 ■ fax 608.839.8731

www.visionfitness.com

© 2009 Vision Fitness. All Rights Reserved. ECB-Plus, HRT, PerfectStride, Quick-Set, Quiet-Glide, SPRINT 8, and Suspension Elliptical are Trademarks of Vision Fitness. May be covered by one or more patents or patents pending; US 5540637, US 5573480, US 5813949, US 5924962, US 5938567, US 6135927, US 6149551, TW 364373, TW 371899, CN 99808486.7

5.09

OM18.57PRD

REV3